



川源(中国)机械有限公司
GSD (China) Co., Ltd.

GHS

**Одноступенчатый горизонтальный
центробежный насос одностороннего
всасывания GHS**

GHS

Одноступенчатый горизонтальный центробежный насос одностороннего всасывания GHS



Особенности

- Одноступенчатый горизонтальный центробежный насос одностороннего всасывания серии GHS разработан в соответствии с EN733 (DIN 24255).
- GHS надежен в эксплуатации, имеет простую и компактную конструкцию, небольшой вес, коррозионную стойкость, низкое энергопотребление. Прост в эксплуатации и обслуживании.
- GHS открываются с задней стороны. Для отсоединения корпуса и рабочего колеса насоса не требуется снятия всасывающего и напорного патрубков.
- Детали насосов серии GHS универсальны и взаимозаменяемы. Все 46 типоразмеров насосов данной серии комплектуются шестью типоразмерами валов. Любые части являются взаимозаменяемыми.
- Насосы с одинаковыми характеристиками могут иметь разную производительность (обозначается буквами А, В, С на моделях насосов) при изменении внешнего диаметра рабочего колеса (подрезке рабочего колеса).
- Насос вращается по часовой стрелке, если смотреть со стороны двигателя.

Применение

Одноступенчатый горизонтальный центробежный насос одностороннего всасывания серии GHS используется для перекачки чистой воды, а также жидкостей с химическими и физическими свойствами, аналогичными воде. Может применяться в системах водоснабжения и водоотведения заводов, шахт и городов, в системах кондиционирования воздуха, пожаротушении и орошении сельскохозяйственных угодий.



Описание основных частей

- Корпус насоса: ножная опорная конструкция со спиральной камерой. Спиральная камера, ножка, впускной фланец и выпускной фланец объединены в единое целое. Фланцы могут быть просверлены в соответствии с метрической или американской системой.
- Рабочее колесо: закрытое рабочее колесо было разработано в отличной гидравлической модели, чтобы гарантировать производительность и эффективность насоса. Необходимо провести проверку динамической балансировки.
- Подвеска (несущая часть): Вилка подвески устанавливается с подшипником внутри. Всего существует 6 типов подшипников для всей серии. Подшипники следует смазывать смазочным маслом или консистентной смазкой.
- Уплотнение вала: торцевое уплотнение. Подходят отечественные и импортные качественные торцевые уплотнения.
- Электродвигатель: при необходимости могут использоваться высококачественные двигатели с низким уровнем шума и вибрации, взрывозащищенные двигатели или иные двигатели с особыми требованиями. Насос приводится в действие непосредственно электродвигателем с упругой муфтой.

Условия эксплуатации

- Выходное отверстие: DN32≈300 мм.
- Мощность: 4,5 ≈ 1660 мВт.
- Напор: 5.2≈150м.
- Скорость вращения: 1450 об/мин и 2900 об / мин (источник питания 50 Гц).
- Температура перекачиваемой среды: -10 - +85 °С (свяжитесь с нами, если температура выходит за указанный диапазон).
- Рабочее давление: 1,6 МПа - стандартное. Возможно увеличение до максимальных 2,5 МПа (пожалуйста, уточняйте в своём заказе).

Конструкция

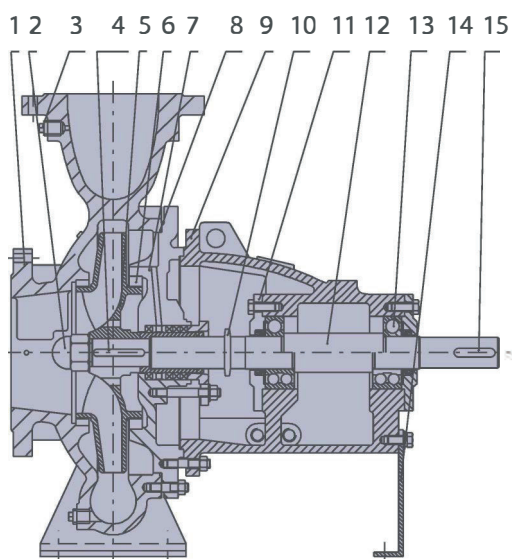

№	Имя	Материал
1	Корпус насоса	HT250 QT400,QT450, ZG07Cr19Ni10,ZG35,ZQA19-4
2	Накидная гайка	HT250
3	Заглушка трубы	HT250
4	Шпонка рабочего колеса	45
5	Рабочее колесо	HT250
6	Уплотнительное кольцо	QT400,QT450,ZG35,ZQSn5-5-5, ZG07cr19Ni10,ZQd19-4
7	Крышка насоса	HT250
8	Уплотнительное кольцо корпуса насоса	
9	Подвеска	HT250
10	Дефлектор воды	NBR
11	Крышка вала	HT250
12	Вал	20Cr13 45,ZG35,1Cr17Ni2
13	Подшипник	
14	Опора подвески	HT250
15	Шпонка насоса	45



Конструкция уплотнительного кольца

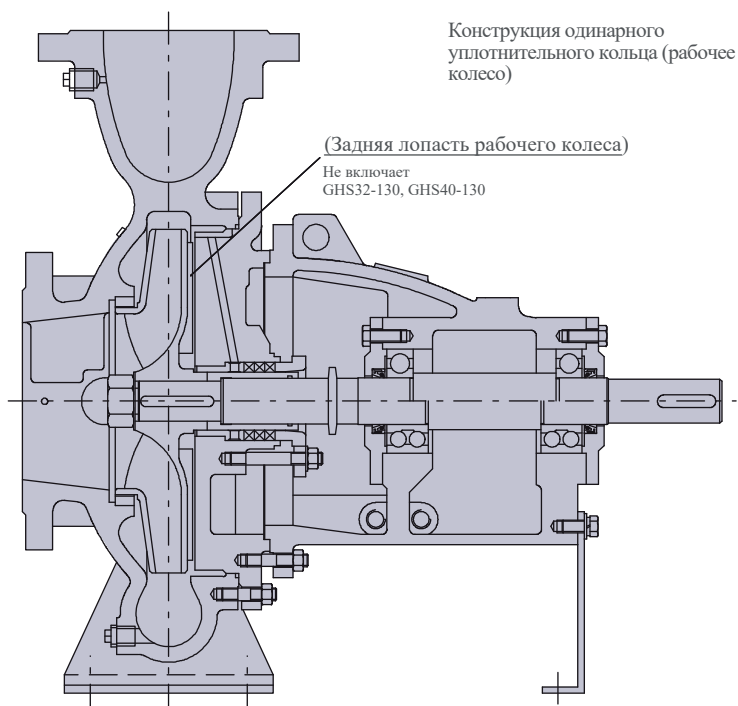

Характеристики

GHS 32-130
GHS 40-130
GHS 50-130
GHS 65-130
GHS 32-160
GHS 40-160
GHS 50-160
GHS 65-160
GHS 80-160
GHS 32-200
GHS 40-200
GHS 50-200
GHS 65-200
GHS 80-200
GHS 100-200
GHS 125-200
GHS 32-260
GHS 40-260
GHS 50-260
GHS 65-260
GHS 80-260
GHS100-260
GHS125-260

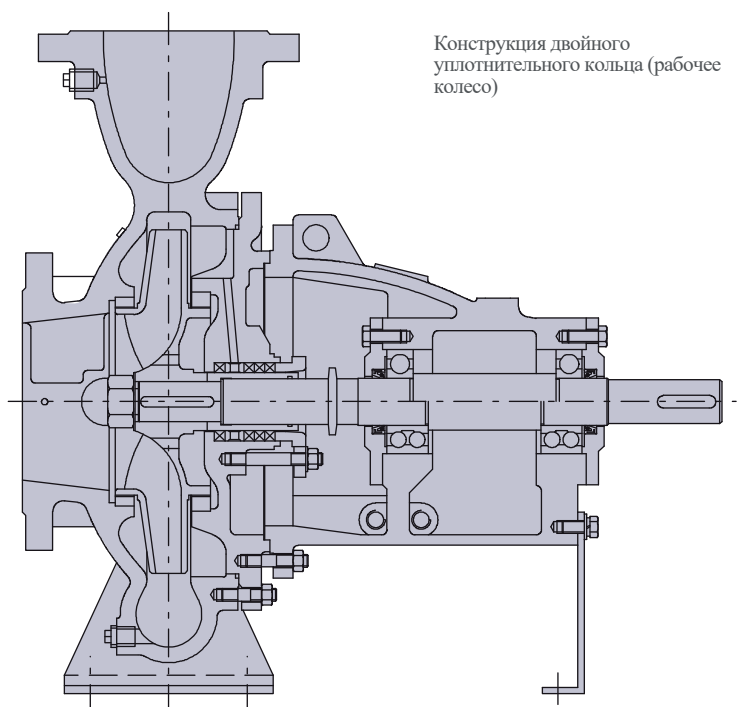

Характеристики

GHS150-200
GHS150-260
GHS200-260
GHS 40-320
GHS 50-320
GHS 65-320
GHS 80-320
GHS100-320
GHS125-320
GHS150-320
GHS200-320
GHS250-320
GHS 80-400
GHS100-400
GHS125-400
GHS150-400
GHS200-400
GHS250-400
GHS300-400
GHS125-500
GHS150-500
GHS200-500
GHS250-500

Конструкция с одинарным уплотнительным кольцом: входная сторона рабочего колеса снабжена уплотнительным кольцом, а задняя часть имеет лопасть для балансировки осевого усилия. Конструкция с двойным уплотнительным кольцом: входная сторона рабочего колеса снабжена уплотнительным кольцом, а задняя часть имеет уплотнительное кольцо и балансировочное отверстие для балансировки осевого усилия.

Конструкция подшипников и режим смазки

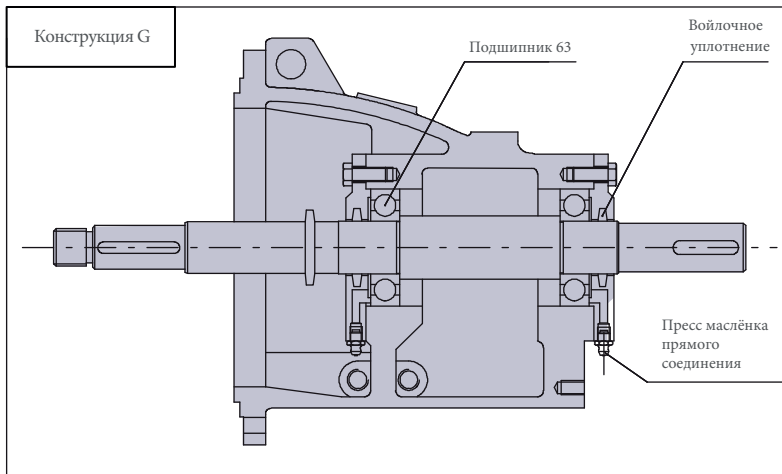

Конструкция G:
Состав консистентной смазки подходит для всех моделей насосов, кроме конструкций H и P (стандарт).

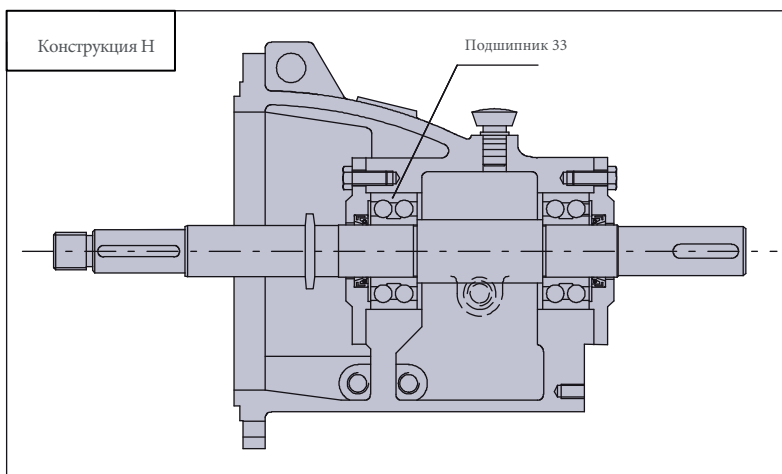

Конструкция H:
Состав масляной смазки,
Подходит только для насосов моделей GHS40-320/2P, GHS50-320/2P, GHS65-320/2P, GHS80-160/2P и GHS80-320/2P.

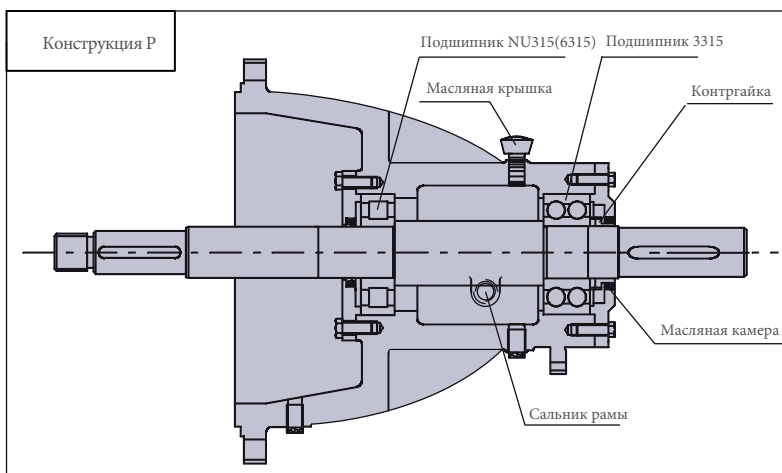

Конструкция P:
Состав масляной смазки (консистентной смазки),
Подходит только для насосов моделей GHS300-320, GHS300-400, GHS250-500.



Конструкция уплотнения

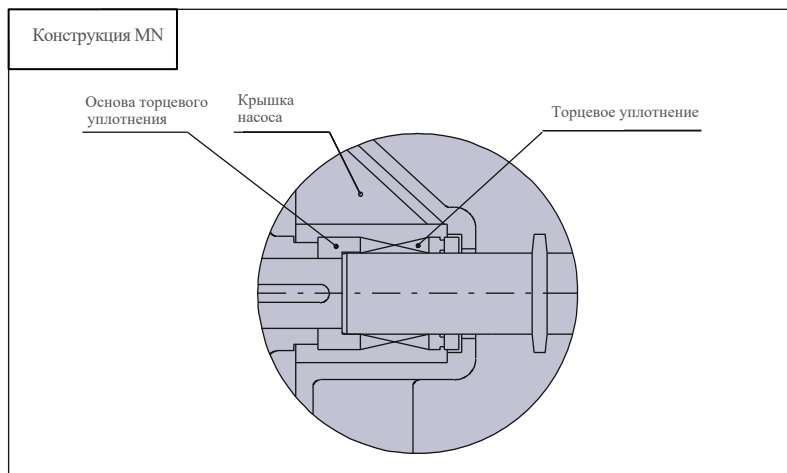

Конструкция MN:
Конструкция неравновесного
внутреннего торцевого уплотнения.

Условное обозначение

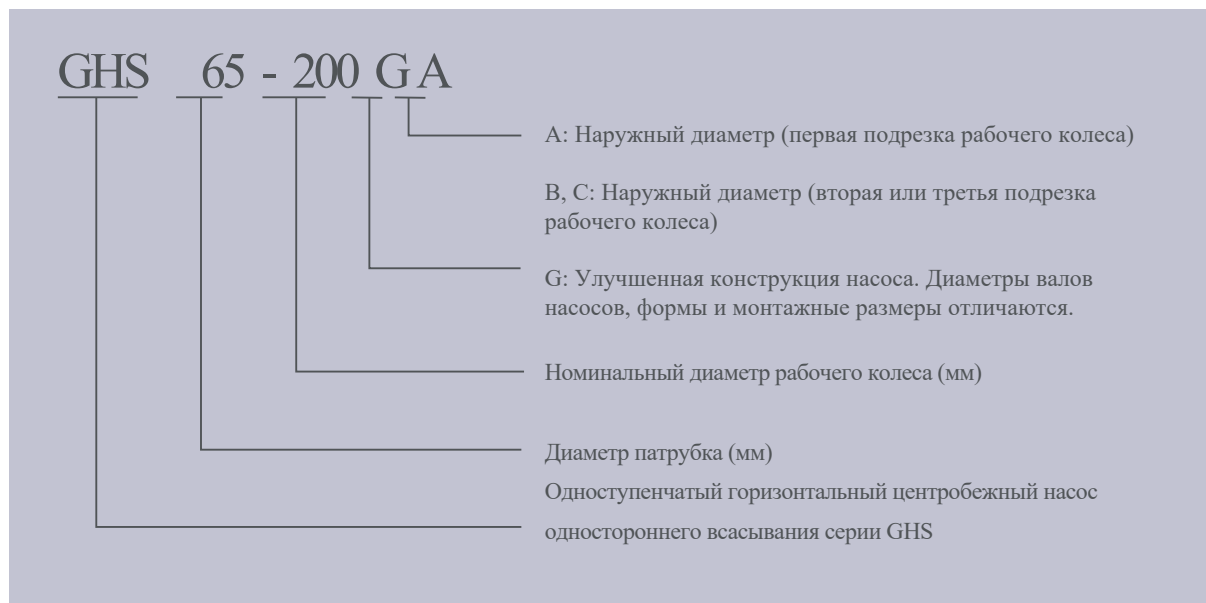

Кривые производительности

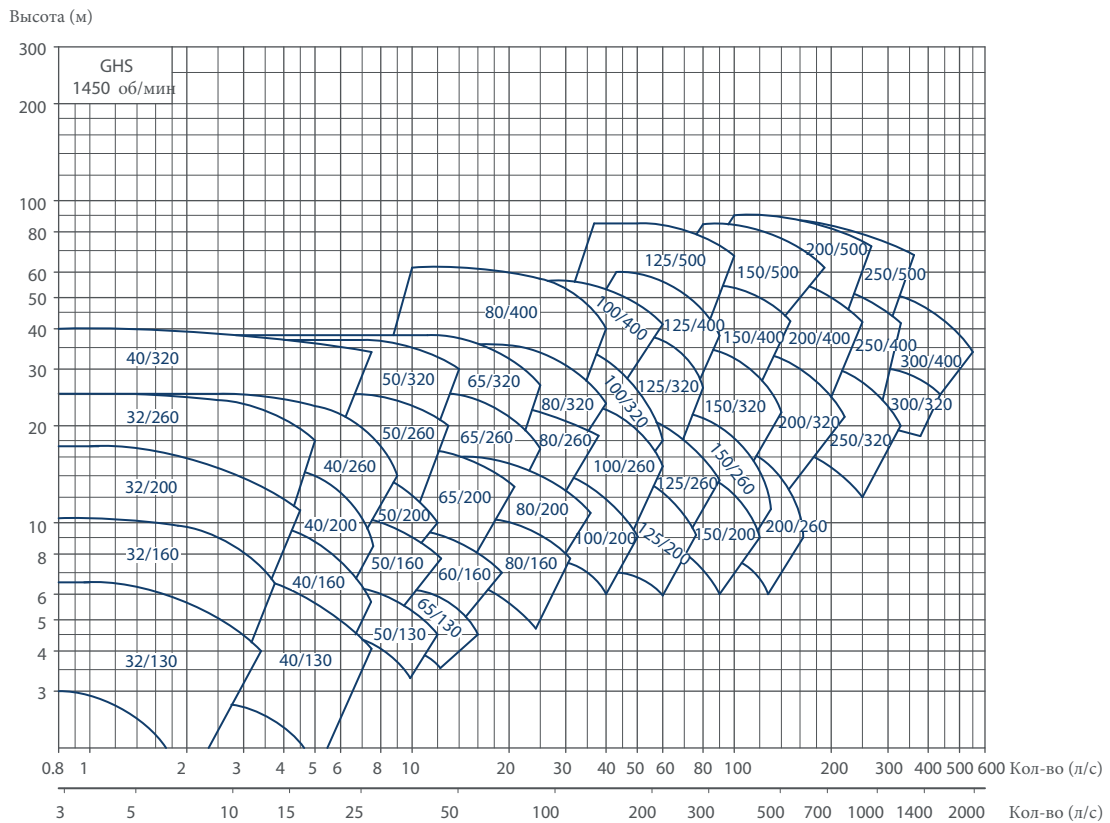
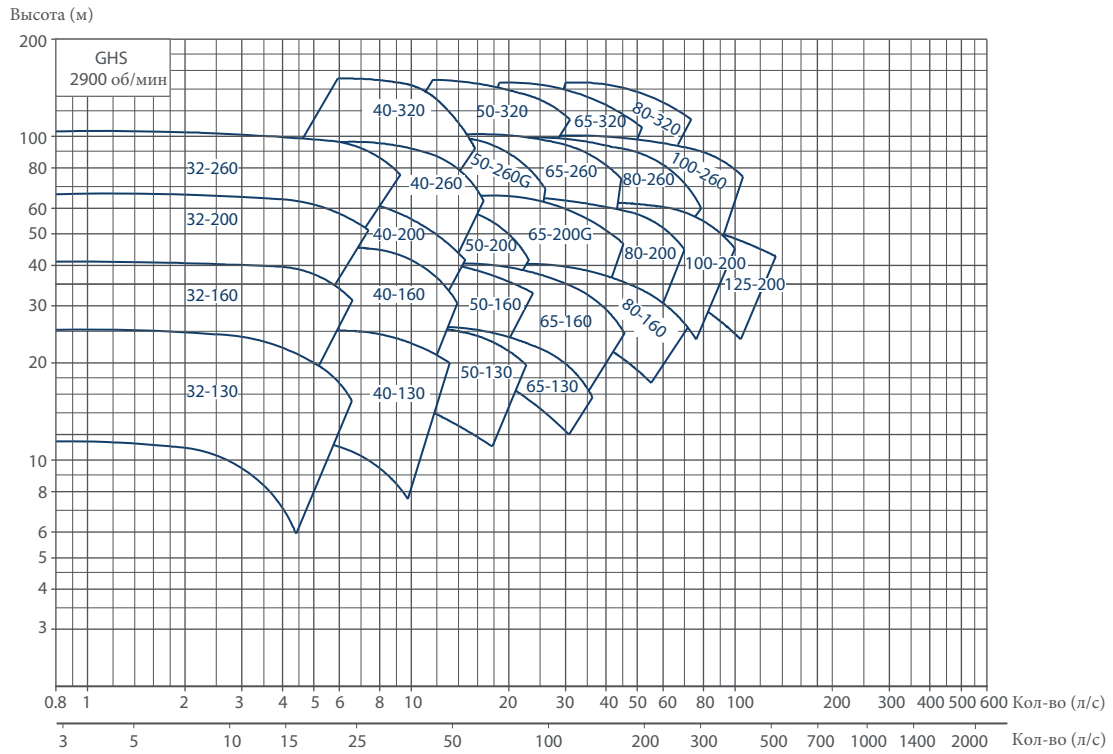

Параметры производительности

(2P)

Модель насоса	Производительность		Напор (м)	Скорость ном. (об/мин)	Мощность		К П Д η (%)	NPSHr (м)	Диаметр насоса (мм)		Вес (кг)
	(м ³ /ч)	(л/с)			Мощность на валу (кВт)	Двигатель (кВт)			Всасывание	Нагнетание	
GHS32-130	9	2.5	24.9	2900	1.23	2.2	44	1.8	50	32	27.5
	15	4.2	23		1.47	2.2	55	2.0			
	18	5.0	21		1.58	2.2	56	2.5			
GHS32-130A	8.5	2.4	21.2	2900	1.04	2.2	43.5	1.8	50	32	27.5
	14	3.9	19		1.23	2.2	54	1.95			
	17	4.7	17.3		1.32	2.2	53	2.3			
GHS32-130B	7.8	2.2	17.3	2900	0.89	1.5	42	1.8	50	32	27.5
	13	3.6	15.3		1.02	1.5	51	1.88			
	15.5	4.3	13.8		1.07	1.5	52	2.08			
GHS32-160	10.8	3.0	40	2900	2.50	5.5	47	1.2	50	32	35
	18	5.0	38.5		3.23	5.5	58.5	2			
	21.6	6.0	36		3.59	5.5	59	2.6			
GHS32-160A	10.5	2.9	35.7	2900	2.22	4	46	1.9	50	32	35
	17	4.7	33		2.78	4	55	1.95			
	21	5.8	30		3.06	4	56	2.4			
GHS32-160B	9.8	2.7	32.4	2900	1.97	4	44	1.9	50	32	35
	16	4.4	29.5		2.43	4	53	1.95			
	19.5	5.4	27		2.66	4	54	2.2			
GHS32-200	10.8	3.0	66	2900	4.51	11	43	1.3	50	32	41
	18	5.0	61.5		5.74	11	52.5	1.9			
	21.6	6.0	57		6.27	11	53.5	2.3			
GHS32-200A	10.2	2.8	58.2	2900	4.04	7.5	40	1.8	50	32	41
	17	4.7	55.8		4.87	7.5	53	1.95			
	20.4	5.7	52.2		5.47	7.5	53	2.2			
GHS32-200B	9.9	2.8	51.5	2900	3.65	7.5	38	1.8	50	32	41
	16.5	4.6	48		4.40	7.5	49	1.9			
	19.8	5.5	45		4.97	7.5	48.8	2.15			
GHS32-260	13.2	3.7	102	2900	11.21	18.5	32.7	1.8	50	32	59
	22	6.1	96		14.10	18.5	40.8	2.7			
	26.4	7.3	89		15.61	18.5	41	3.3			
GHS32-260A	12.6	3.5	92.5	2900	10.11	15	31.4	2.1	50	32	59
	21	5.8	88		12.58	15	40	2.2			
	25.2	7.0	83		13.89	15	41	2.5			
GHS32-260B	12.3	3.4	84.5	2900	9.43	15	30	2.15	50	32	59
	20.5	5.7	81		11.75	15	38.5	2.16			
	24.6	6.8	77		12.90	15	40	2.38			
GHS40-130	18	5.0	26	2900	2.09	4	61	1.8	65	40	30
	30	8.3	24.5		2.65	4	75.5	2.0			
	36	10.0	23		2.91	4	77.5	2.4			
GHS40-130A	16.8	4.7	22.5	2900	1.74	4	59	1.8	65	40	30
	28	7.8	21		2.29	4	70	2			
	33.6	9.3	20		2.54	4	72	2.25			
GHS40-130B	15.5	4.3	18.5	2900	1.47	3	53	1.8	65	40	30
	26	7.2	17.5		1.91	3	65	1.9			
	31	8.6	16.5		2.14	3	65	2.15			
GHS40-160	18	5.0	41	2900	3.72	7.5	54	2.1	65	40	36
	30	8.3	38.5		4.91	7.5	64	2.5			
	36	10.0	35.5		5.40	7.5	64.5	3.6			
GHS40-160A	17	4.7	36	2900	3.21	5.5	52	2.1	65	40	36
	28.5	7.9	33.5		4.00	5.5	65	2.5			
	34	9.4	31		4.63	5.5	62	3.25			
GHS40-160B	16	4.4	31.5	2900	2.86	4	48	2.05	65	40	36
	26.5	7.4	29		3.52	4	62	2.4			
	32	8.9	25.5		3.77	4	59	2.9			
GHS40-200	18	5.0	64	2900	6.54	11	48	1.85	65	40	44
	30	8.3	61		8.38	11	59.5	2.0			
	36	10.0	58.6		9.27	11	62	2.7			
GHS40-200A	17	4.7	58.5	2900	5.58	11	48.5	1.8	65	40	44
	29	8.1	56		7.25	11	61	1.95			
	34.5	9.6	53.5		7.98	11	63	2.45			
GHS40-200B	16.5	4.6	52.5	2900	5.13	11	46	1.8	65	40	44
	27.5	7.6	49		6.22	11	59	1.9			
	33	9.2	47		6.92	11	61	2.2			
GHS40-260	21.6	6.0	98.5	2900	12.88	22	45	1.8	65	40	61
	36	10.0	95.5		16.72	22	56	2.0			
	43.2	12.0	91		18.15	22	59	2.5			
GHS40-260A	19.5	5.4	89	2900	11.25	18.5	42	1.8	65	40	61
	32	8.9	87		14.31	18.5	53	1.95			
	38.5	10.7	84		16.01	18.5	55	2.35			



Параметры производительности

(2P)

Модель насоса	Производительность		Напор (м)	Скорость ном. (об/мин)	Мощность		К П Д η (%)	NPSHr (м)	Диаметр насоса (мм)		Вес (кг)
	(м ³ /ч)	(л/с)			Мощность на валу (кВт)	Двигатель (кВт)			Всасывание	Нагнетание	
GHS40-260B	18.5	5.1	80	2900	10.08	18.5	40	1.8	65	40	61
	30.5	8.5	78		12.22	18.5	53	1.9			
	37	10.3	76		14.18	18.5	54	2.2			
GHS40-320	21.6	6.0	150	2900	25.95	37	34	2	65	40	95.8
	36	10.0	139		30.97	37	44	2.8			
	43.2	12.0	127		33.20	37	45	3.8			
GHS40-320A	19.44	5.4	124	2900	19.31	30	34	1.9	65	40	95.8
	32.4	9.0	115		23.60	30	43	2.9			
	38.88	10.8	107		25.75	30	44	3.8			
GHS40-320B	17.28	4.8	109	2900	16.03	22	32	1.7	65	40	95.8
	28.8	8.0	102		19.51	22	41	2.6			
	34.56	9.6	95		21.29	22	42	3.2			
GHS50-130	36	10.0	26	2900	3.78	7.5	67.5	2.5	65	50	34
	60	16.7	23.5		5.05	7.5	76	3.2			
	72	20.0	21.5		5.66	7.5	74.5	4			
GHS50-130A	33.5	9.3	21.5	2900	3.04	5.5	64.5	2.5	65	50	34
	56	15.6	18.5		4.00	5.5	70.5	3.1			
	67.5	18.8	15.5		4.35	5.5	65.5	3.6			
GHS50-130B	31	8.6	18.5	2900	2.56	5.5	61	2.5	65	50	34
	52	14.4	16.5		3.34	5.5	70	2.9			
	62	17.2	15		3.67	5.5	69	3.3			
GHS50-160	40	11.1	42.5	2900	6.76	11	68.5	2.5	65	50	38
	65	18.1	39		9.08	11	76	3.5			
	78	21.7	35.5		10.26	11	73.5	4.2			
GHS50-160A	38	10.6	38	2900	5.62	11	70	2.5	65	50	38
	61.5	17.1	34.5		7.60	11	76	3.3			
	74	20.6	30		8.17	11	74	3.9			
GHS50-160B	35.5	9.9	34	2900	4.63	11	71	2.35	65	50	38
	58	16.1	30.5		6.42	11	75	3.1			
	69.5	19.3	28		7.26	11	73	3.7			
GHS50-200	36	10.0	61	2900	9.34	18.5	64	1.9	65	50	46
	60	16.7	55		12.84	18.5	70	3.2			
	72	20.0	51		14.39	18.5	69.5	4.1			
GHS50-200A	34.5	9.6	57	2900	8.93	15	60	2.5	65	50	46
	57.5	16.0	53		11.53	15	72	3.1			
	69	19.2	50.5		13	15	73	3.75			
GHS50-200B	33	9.2	49.5	2900	7.18	15	62	2.5	65	50	46
	54.5	15.1	43		9.39	15	68	3.0			
	65.5	18.2	38		10.27	15	66	3.5			
GHS50-260	40	11.1	103	2900	20.78	37	54	2.5	65	50	63
	65	18.1	97.5		27.18	37	63.5	3.5			
	78	21.7	91		30.68	37	63	4.2			
GHS50-260A	38.5	10.7	91.5	2900	19.19	30	50	2.4	65	50	63
	63	17.5	85.5		24.45	30	60	3.3			
	75.5	21.0	80		26.75	30	61.5	3.9			
GHS50-260B	37	10.3	84	2900	16.93	30	50	2.3	65	50	63
	60.5	16.8	77		21.14	30	60	3.2			
	72.5	20.1	71		24.17	30	58	3.9			
GHS50-320	54	15.0	146	2900	40.51	75	53	3.5	65	50	101
	90	25.0	137		55.05	75	61	7.0			
	108	30.0	130		61.67	75	62	8.0			
GHS50-320A	48.6	13.5	130	2900	34.41	75	50	3.3	65	50	101
	81	22.5	124		45.59	75	60	6.5			
	97.2	27.0	117		50.77	75	61	7.5			
GHS50-320B	46.8	13.0	105	2900	25.74	45	52	2.5	65	50	101
	78.12	21.7	98		35.04	45	59.5	5.0			
	93.6	26.0	91		39.32	45	59	6.5			
GHS65-130	60	16.7	25.5	2900	6.27	11	69	3.0	80	65	39
	100	27.8	21		8.17	11	70	3.5			
	120	33.3	16		8.86	11	59	4.5			
GHS65-130A	56	15.6	21.8	2900	5.11	11	65	3	80	65	39
	93.5	26.0	17.5		6.37	11	70	3.5			
	112.5	31.3	13		6.99	11	57	4.1			
GHS65-130B	52	14.4	18	2900	4.08	7.5	62.5	3	80	65	39
	86.5	24.0	13.7		4.89	7.5	66	3.3			
	104	28.9	10.6		5.27	7.5	57	3.75			
GHS65-160	64.8	18.0	39	2900	9.97	18.5	69	3.6	80	65	43
	108	30.0	33.5		12.71	18.5	77.5	4.2			
	129.6	36.0	29		14.22	18.5	72	5.2			



Параметры производительности

(2P)

Модель насоса	Производительность		Напор (м)	Скорость ном. (об/мин)	Мощность		К П Д η (%)	NPSHr (м)	Диаметр насоса (мм)		Вес (кг)
	(м ³ /ч)	(л/с)			Мощность на валу (кВт)	Двигатель (кВт)			Всасывание	Нагнетание	
GHS65-160A	57	15,8	34	2900	8,38	15	63	3,6	80	65	43
	95	26,4	30,5		10,66	15	74	4,1			
	114	31,7	27		11,81	15	71	4,8			
GHS65-160B	53,5	14,9	30	2900	7,28	11	60	3,6	80	65	43
	89	24,7	25,5		8,83	11	70	3,95			
	107	29,7	22,5		9,50	11	69	4,5			
GHS65-200G	66	18,3	64	2900	17,7	30	65	3,0	80	65	70
	110	30,6	59		23,72	30	74,5	3,9			
	132	36,7	54,5		26,66	30	73,5	5,3			
GHS65-200GA	63	17,5	60	2900	16,08	30	64	3,0	80	65	70
	105,5	29,3	55,5		21,55	30	74	3,9			
	126,5	35,1	52		24,37	30	73,5	5,3			
GHS65-200GB	60	16,7	50	2900	13,18	22	62	3,0	80	65	70
	100	27,8	45,5		16,41	22	75,5	3,6			
	120	33,3	42		18,30	22	75	4,4			
GHS65-260	72	20,0	98	2900	29,79	55	64,5	3,3	80	65	81
	120	33,3	90		42,29	55	73	4,5			
	144	40,0	83		44,59	55	73	5,4			
GHS65-260A	69,5	19,3	92	2900	26,79	45	65	3,25	80	65	81
	116	32,2	86		38,81	45	70	4,4			
	139	38,6	79		41,53	45	72	4,95			
GHS65-260B	67	18,6	82,5	2900	23,89	45	63	3,2	80	65	81
	111,5	31,0	76		32,50	45	71	4,25			
	133,5	37,1	71		36,88	45	70	4,95			
GHS65-320H	81	22,5	147	2900	60,05	110	54	3,8	80	65	110
	135	37,5	131		76,45	110	63	4,4			
	162	45,0	115		84,56	110	60	5,5			
GHS65-320HA	81	22,5	120	2900	48,13	90	55	3,7	80	65	110
	135	37,5	108		64,04	90	62	4,3			
	162	45,0	97		73,78	90	58	5,2			
GHS65-320HB	81	22,5	107	2900	40,00	75	59	3,5	80	65	110
	135	37,5	94		56,65	75	61	4,3			
	162	45,0	83		67,81	75	54	4,8			
GHS80-160	100	27,8	39,5	2900	15,15	30	71	3,3	100	80	54
	162	45,0	35		19,80	30	78	4,0			
	195	54,2	31		21,95	30	75	5,0			
GHS80-160A	95	26,4	33	2900	13,13	22	65	3,3	100	80	54
	153,5	42,6	28		16,26	22	72	3,85			
	185	51,4	24		17,78	22	68	4,6			
GHS80-160B	89	24,7	29,5	2900	11,17	18,5	64	3,25	100	80	54
	144,5	40,1	25		13,29	18,5	74	3,7			
	174	48,3	21		14,22	18,5	70	4,3			
GHS80-200	115	31,9	60	2900	26,84	45	70	4,0	100	80	70
	190	52,8	55		36,49	45	78	5,1			
	225	62,5	50		41,12	45	74,5	6,2			
GHS80-200A	110	30,6	57	2900	25,11	37	68	4,0	100	80	70
	182	50,6	53,5		34,44	37	77	4,9			
	215,5	59,9	44,5		37,31	37	70	5,85			
GHS80-200B	105	29,2	49,5	2900	20,82	37	68	4,0	100	80	70
	173	48,1	45		27,90	37	76	4,7			
	205	56,9	40		31,90	37	70	5,5			
GHS80-260	115	31,9	97	2900	46,74	75	65	4,0	100	80	91
	190	52,8	88		60,71	75	75	5,4			
	225	62,5	81		67,53	75	73,5	6,5			
GHS80-260A	111	30,8	91,5	2900	43,90	75	63	3,95	100	80	91
	183,5	51,0	81,5		54,30	75	75	5,2			
	217,5	60,4	73		59,23	75	73	6,25			
GHS80-260B	106,5	29,6	79	2900	37,56	75	61	3,9	100	80	91
	176,5	49,0	68,5		45,10	75	73	5			
	209	58,1	60		48,10	75	71	6			
GHS80-320H	126	35,0	146	2900	78,28	132	64	5,6	100	80	120
	210	58,3	134		103,56	132	74	6,3			
	252	70,0	121		113,75	132	73	7			
GHS80-320HA	117	32,5	125	2900	64,24	110	62	6,1	100	80	120
	195	54,2	114		82,93	110	73	6,3			
	234	65,0	103		91,16	110	72	6,9			
GHS80-320HB	108	30,0	104	2900	47,79	90	64	5	100	80	120
	180	50,0	95		63,79	90	73	5,8			
	216	60,0	85		71,43	90	70	6,3			



Параметры производительности

(2P/4P)

Модель насоса	Производительность		Напор (м)	Скорость ном. (об/мин)	Мощность		К П Д η (%)	NPSHr (м)	Диаметр насоса (мм)		Вес (кг)
	(м ³ /ч)	(л/с)			Мощность на валу (кВт)	Двигатель (кВт)			Всасывание	Нагнетание	
GHS100-200	180	50.0	61	2900	41.53	75	72	4.0	125	100	85
	295	81.9	51.5		52.37	75	79	5.3			
	340	94.4	42		52.55	75	74	6.3			
GHS100-200A	172.5	47.9	51	2900	34.72	55	69	3.95	125	100	85
	273	75.8	42		42.20	55	74	4.9			
	325.5	90.4	36		46.25	55	69	5.95			
GHS100-200B	164	45.6	46	2900	30.21	45	68	3.9	125	100	85
	260	72.2	35		35.40	45	70	4.8			
	310	86.1	31		39.06	45	67	5.6			
GHS100-260H	190	52.8	97	2900	70.69	110	71	3.8	125	100	106
	295	81.9	86		90.91	110	76	5.2			
	350	97.2	80		103.04	110	74	6.5			
GHS100-260HA	183.5	51.0	85.5	2900	61.92	110	69	3.75	125	100	106
	285	79.2	75		78.66	110	74	5			
	338	93.9	66		85.57	110	71	6.2			
GHS100-260HB	177	49.2	76	2900	54.68	90	67	3.7	125	100	106
	274	76.1	66		68.4	90	72	4.8			
	325	90.3	58		75.49	90	68	5.9			
GHS125-200	237.6	66.0	57.5	2900	57.68	90	64.5	7	150	125	106
	360	100.0	50.5		66.46	90	74.5	7.2			
	475.2	132.0	40		76.12	90	68	7.8			
GHS32-130	4.5	1.3	6.2	1450	0.22	0.55	35	1.8	50	32	27.5
	7.5	2.1	5.6		0.25	0.55	46	2.0			
	9	2.5	5.2		0.26	0.55	49	2.3			
GHS32-160	6	1.7	9.7	1450	0.38	0.55	42	0.7	50	32	35
	9	2.5	9		0.46	0.55	48	1.0			
	11	3.1	8		0.48	0.55	49.5	1.4			
GHS32-200	6	1.7	16.3	1450	0.67	1.1	40	1.8	50	32	41
	9	2.5	15.4		0.79	1.1	48	2.0			
	11	3.1	14.5		0.85	1.1	51	2.3			
GHS32-260	7.2	2.0	25	1450	1.63	3	30	1.8	50	32	59
	12	3.3	23.5		1.94	3	39.5	2.0			
	14.4	4.0	22		2.05	3	42	2.3			
GHS40-130	10.8	3.0	6.55	1450	0.34	0.55	57	1.8	65	40	30
	18	5.0	5.8		0.42	0.55	67	2.0			
	21.6	6.0	5.4		0.47	0.55	67	2.4			
GHS40-160	10.8	3.0	10.2	1450	0.55	1.1	55	1.8	65	40	36
	18	5.0	8.8		0.70	1.1	62	2.0			
	21.6	6.0	7.8		0.76	1.1	60	2.4			
GHS40-200	10.8	3.0	16.2	1450	0.95	1.5	50	1.8	65	40	44
	18	5.0	14		1.23	1.5	56	2.0			
	21.6	6.0	12.4		1.33	1.5	55	2.4			
GHS40-260	12.6	3.5	24.4	1450	1.99	3	42	1.8	65	40	61
	21	5.8	22		2.42	3	52	2.0			
	25.2	7.0	20		2.61	3	52.5	2.4			
GHS40-320	9	2.5	38	1450	3.10	5.5	30	3.1	65	40	95.8
	14.4	4.0	37.5		3.50	5.5	42	2.1			
	18	5.0	37		4.03	5.5	45	3.8			
GHS40-320A	10.5	2.9	34.5	1450	3.23	5.5	30.5	3.3	65	40	95.8
	17	4.7	32		3.85	5.5	38.5	2			
	20.5	5.7	29		4.32	5.5	37.5	2.9			
GHS40-320B	10	2.8	31	1450	2.91	5.5	29	3.6	65	40	95.8
	16.5	4.6	29		3.52	5.5	37	2			
	20	5.6	26		3.93	5.5	36	2.7			
GHS50-130	18	5.0	6.6	1450	0.54	1.1	60	2.2	65	50	34
	30	8.3	6.3		0.68	1.1	75.5	2.4			
	36	10.0	5.7		0.76	1.1	74	2.8			
GHS50-160	20	5.6	10.4	1450	0.89	1.5	64	2.3	65	50	38
	32	8.9	9.8		1.15	1.5	74.3	2.4			
	38	10.6	9.4		1.31	1.5	74.5	3.0			
GHS50-200	18	5.0	16	1450	1.35	2.2	58	2.2	65	50	46
	30	8.3	14		1.79	2.2	64	2.3			
	36	10.0	13.5		2.04	2.2	65	2.9			
GHS50-260	20	5.6	25	1450	2.59	5.5	52.5	2.3	65	50	63
	32	8.9	24		3.24	5.5	64.5	2.4			
	38	10.6	23		3.58	5.5	66.5	3.0			
GHS50-320	32.4	9.0	30.7	1450	5.78	11	56.5	2.0	65	50	101
	54	15.0	37.5		7.80	11	57.5	2.5			
	64.8	18.0	23.5		8.73	11	47.5	3.2			



Параметры производительности

(4P)

Модель насоса	Производительность		Напор (м)	Скорость ном. (об/мин)	Мощность		К П Д η (%)	NPSHr (м)	Диаметр насоса (мм)		Вес (кг)
	(м ³ /ч)	(л/с)			Мощность на валу (кВт)	Двигатель (кВт)			Всасывание	Нагнетание	
GHS50-320A	23	6.4	33.5	1450	4.20	7.5	50	2.0	65	50	101
	38.5	10.7	31.3		5.29	7.5	62	2.4			
	46	12.8	30		5.97	7.5	63	3.0			
GHS50-320B	22	6.1	29.8	1450	3.57	7.5	50	2.0	65	50	101
	36.5	10.1	28.5		4.64	7.5	61	2.3			
	44	12.2	27		5.22	7.5	62	2.8			
GHS65-130	21.6	6.0	6.7	1450	0.79	1.5	50	2.2	80	65	39
	36	10.0	6.4		0.95	1.5	66	2.4			
	43.2	12.0	6		1.02	1.5	69	2.8			
GHS65-160	32.4	9.0	10	1450	1.38	2.2	64	2.0	80	65	43
	54	15.0	9.2		1.73	2.2	78	2.2			
	64.8	18.0	8.4		1.82	2.2	81.5	2.5			
GHS65-200	35	9.7	16.4	1450	2.37	4	66	1.9	80	65	52
	55	15.3	15		2.94	4	76.5	2.0			
	66	18.3	13.8		3.20	4	77.5	2.3			
GHS65-260	43.2	12.0	25.3	1450	4.48	7.5	66.5	2.0	80	65	81
	72	20.0	21.5		5.74	7.5	73.5	2.3			
	86.4	24.0	18.7		6.47	7.5	68	3.0			
GHS65-320	43.2	12.0	37.4	1450	7.46	15	59	1.9	80	65	110
	72	20.0	33		9.66	15	67	2.0			
	86.4	24.0	29		10.50	15	65	2.5			
GHS65-320A	37	10.3	34.5	1450	6.32	11	55	1.9	80	65	110
	62	17.2	32		8.31	11	65	2.0			
	74.5	20.7	28		9.16	11	62	2.3			
GHS65-320B	34	9.4	30.5	1450	6.01	11	47	2.0	80	65	110
	56.5	15.7	28		7.30	11	59	2.0			
	68	18.9	25.8		8.10	11	59	2.1			
GHS80-160	50	13.9	10.6	1450	2.31	4	62.5	2.1	100	80	54
	80	22.2	10		2.87	4	76	2.5			
	96	26.7	9.3		3.16	4	77	3.2			
GHS80-200	63	17.5	15.7	1450	3.59	7.5	75	2.1	100	80	70
	105.12	29.2	14		4.89	7.5	82	2.5			
	126	35.0	12.8		5.63	7.5	78	3.2			
GHS80-260	63	17.5	24	1450	5.88	11	70	2.1	100	80	91
	105.12	29.2	21		7.91	11	76	2.5			
	126	35.0	18.5		8.82	11	72	3.2			
GHS80-320	60	16.7	36	1450	9.41	18.5	62.5	1.9	100	80	120
	100	27.8	33		12.66	18.5	71	2.0			
	120	33.3	30		14.11	18.5	69.5	2.6			
GHS80-320A	57.5	16.0	34	1450	9.18	15	58	1.9	100	80	120
	95.5	26.5	29.7		11.19	15	69	2.0			
	114.5	31.8	26		11.92	15	68	2.3			
GHS80-320B	54.5	15.1	30.4	1450	8.06	15	56	1.9	100	80	120
	91	25.3	27.3		10.10	15	67	2.0			
	109	30.0	25		11.24	15	66	2.2			
GHS80-400	60	16.7	59	1450	17.37	30	55.5	2.2	100	80	161
	100	27.8	55.5		23.08	30	65.5	2.5			
	120	33.3	52.5		25.80	30	66.5	3.4			
GHS80-400A	59	16.4	55	1450	16.07	30	55	2.2	100	80	161
	96.5	26.8	52.5		21.56	30	64	2.4			
	116	32.2	49		24.57	30	63	3.2			
GHS80-400B	56	15.6	51	1450	14.40	30	54	2.2	100	80	161
	93	25.8	49		18.80	30	66	2.4			
	111.5	31.0	47		20.99	30	68	3.0			
GHS100-200	90	25.0	15	1450	4.60	11	80	2.2	125	100	85
	142	39.4	12.7		5.99	11	82	2.5			
	170	47.2	10.5		6.52	11	74.5	3.4			
GHS100-260	99	27.5	24	1450	8.51	15	76	2.3	125	100	115
	165	45.8	21		11.58	15	81.5	2.6			
	198	55.0	19		13.66	15	75	3.5			
GHS100-320	81	22.5	39	1450	11.95	22	72	2.0	125	100	134
	135	37.5	33.7		15.49	22	80	2.0			
	162	45.0	30		17.30	22	76.5	2.3			
GHS100-320A	77.5	21.5	34	1450	10.25	22	70	2.0	125	100	134
	130	36.1	29.5		13.74	22	76	2.0			
	155	43.1	26.5		15.32	22	73	2.2			
GHS100-320B	73.5	20.4	30	1450	8.96	18.5	67	2.0	125	100	134
	123	34.2	27		11.90	18.5	76	2.0			
	147.5	41.0	23		13.01	18.5	71	2.1			



Параметры производительности

(4P)

Модель насоса	Производительность		Напор (м)	Скорость ном. (об/мин)	Мощность		К П Д η (%)	NPSHr (м)	Диаметр насоса (мм)		Вес (кг)
	(м3/ч)	(л/с)			Мощность на валу (кВт)	Двигатель (кВт)			Всасывание	Нагнетание	
GHS100-400	90	25.0	58.8	1450	23.82	45	60.5	1.7	125	100	174
	150	41.7	51		30.86	45	67.5	2.0			
	180	50.0	44		33.44	45	64.5	2.7			
GHS100-400A	87	24.2	54	1450	22.85	37	56	1.7	125	100	174
	145	40.3	48.2		28.84	37	66	2.0			
	174	48.3	42		29.97	37	66.4	2.5			
GHS100-400B	84	23.3	49.5	1450	20.97	37	54	1.7	125	100	174
	139.5	38.8	45.2		26.83	37	64	1.9			
	167.5	46.5	41.2		29.36	37	64	2.4			
GHS125-200	115	31.9	15.2	1450	7.68	11	62	2.6	150	125	106
	190	52.8	13		8.74	11	77	3.5			
	230	63.9	11.5		9.42	11	76.5	3.0			
GHS125-260	144	40.0	24.2	1450	12.82	22	74	2.3	150	125	106
	240	66.7	21.2		17.11	22	81	2.5			
	288	80.0	17		18.52	22	72	3.2			
GHS125-260A	139	38.6	21.3	1450	11.86	22	68	2.3	150	125	106
	232	64.4	18.2		14.56	22	79	2.5			
	278.5	77.4	15.4		15.57	22	75	3.0			
GHS125-260B	134	37.2	19.7	1450	9.71	18.5	74	2.3	150	125	106
	223	61.9	16		12.79	18.5	76	2.4			
	267.5	74.3	13.4		14.36	18.5	68	2.8			
GHS125-320	120	33.3	35	1450	16.95	30	67.5	2.1	150	125	163
	200	55.6	32.5		22.41	30	79	2.0			
	240	66.7	30		25.14	30	78	2.7			
GHS125-320A	115	31.9	32.8	1450	15.11	30	68	2.15	150	125	163
	191	53.1	29.5		19.93	30	77	1.95			
	229	63.6	27.5		22.87	30	75	2.4			
GHS125-320B	109	30.3	28.9	1450	11.83	22	72.5	2.2	150	125	163
	182	50.6	25.2		16.43	22	76	2.0			
	218.5	60.7	12.9		10.37	22	74	2.2			
GHS125-400	144	40.0	59.5	1450	30.30	75	77	2.2	150	125	101
	245	68.1	52		45.35	75	76.5	2.4			
	300	83.3	45		52.15	75	70.5	3.0			
GHS125-400A	139	38.6	53.5	1450	31.40	55	64.5	2.2	150	125	181
	236.5	65.7	46		40.04	55	74	2.4			
	289	80.3	38.5		45.23	55	67	3.0			
GHS125-400B	133.5	37.1	51.2	1450	29.08	55	64	2.2	150	125	181
	227.5	63.2	40		35.15	55	70.5	2.3			
	278.5	77.4	32.5		40.41	55	61	2.8			
GHS125-500	150	41.7	83.5	1450	54.14	110	63	2.3	150	125	390
	250	69.4	78		75.86	110	70	2.5			
	300	83.3	72		90.50	110	65	2.6			
GHS125-500A	135	37.5	78.5	1450	48.10	75	60	1.8	150	125	390
	225	62.5	75		62.10	75	74	2.1			
	270	75.0	71		68.69	75	76	2.5			
GHS125-500B	120	33.3	75	1450	45.39	75	54	1.6	150	125	390
	200	55.6	72		58.53	75	67	2.0			
	240	66.7	69		64.43	75	70	2.4			
GHS125-500C	90	25.0	67	1450	32.84	55	50	1.6	150	125	309
	150	41.7	65.5		41.81	55	64	2.0			
	180	50.0	62		45.36	55	67	2.4			
GHS150-200	216	60.0	14.4	1450	12.10	18.5	70	3.0	200	150	156
	360	100.0	12.2		14.95	18.5	80	3.5			
	424.8	118.0	10.3		15.47	18.5	77	4.0			
GHS150-200A	172.8	48.0	13.4	1450	9.27	15	68	3.1	200	150	156
	288	80.0	12		12.07	15	78	3.8			
	345.6	96.0	10.5		13.00	15	76	4.2			
GHS150-260	194	53.9	23.5	1450	16.55	30	75	2.7	200	150	148
	324	90.0	20.5		22.06	30	82	3.0			
	414	115.0	16		26.53	30	68	3.3			
GHS150-260A	180	50.0	21.2	1450	14.43	30	72	2.6	200	150	148
	300	83.3	19		19.53	30	79.5	2.9			
	388.8	108.0	14.5		22.58	30	68	3.3			
GHS150-260B	162	45.0	19	1450	11.33	22	74	2.6	200	150	148
	270	75.0	16.5		15.36	22	79	2.8			
	342	95.0	12.5		17.12	22	68	3.2			
GHS150-320	230	63.9	36.5	1450	30.89	55	74	2.8	200	150	170
	370	102.8	33		41.05	55	81	3.2			
	445	123.6	28.5		46.05	55	75	3.6			



Параметры производительности

(4P)

Модель насоса	Производительность		Напор (м)	Скорость ном. (об/мин)	Мощность		К П Д η (%)	NPSHr (м)	Диаметр насоса (мм)		Вес (кг)
	(м ³ /ч)	(л/с)			Мощность на валу (кВт)	Двигатель (кВт)			Всасывание	Нагнетание	
GHS150-320A	220	61.1	33.4	1450	27.79	45	72	2.8	200	150	170
	354	98.3	29.3		35.76	45	79	3.1			
	426	118.3	25		39.19	45	74	3.5			
GHS150-320B	209.5	58.2	30	1450	24.11	37	71	2.8	200	150	170
	337.5	93.8	26		31.04	37	77	3			
	405.5	112.6	21.9		33.13	37	73	3.3			
GHS150-400	240	66.7	58	1450	50.54	90	75	2.8	200	150	209
	385	106.9	53.5		66.78	90	84	3.2			
	460	127.8	49		73.96	90	83	3.6			
GHS150-400A	232	64.4	52	1450	45.63	75	72	2.8	200	150	209
	372	103.3	47.5		61.69	75	78	3.2			
	444	123.3	42.5		66.74	75	77	3.6			
GHS150-400B	223	61.9	48	1450	41.64	75	70	2.8	200	150	209
	357.5	99.3	43.5		55.72	75	76	3.1			
	427.5	118.8	39		61.36	75	74	3.5			
GHS150-500	300	83.3	86.5	1450	89.5	160	79	3.1	200	150	410
	500	138.9	77.5		125.6	160	84	3.5			
	600	166.7	69		139.2	160	81	3.8			
GHS150-500A	270	75	79.5	1450	79.0	132	74	3.0	200	150	410
	450	125.0	72		110.3	132	80	3.4			
	540	150.0	63		120.3	132	77	3.6			
GHS150-500B	240	66.7	75.5	1450	71.5	132	69	2.8	200	150	410
	400	111.1	70		96.5	132	79	3.2			
	480	133.3	65		108.9	132	78	3.5			
GHS150-500C	210	58.3	68	1450	58.0	110	67	2.6	200	150	410
	350	97.2	63		78.0	110	77	3.0			
	420	116.7	60.5		91.1	110	76	3.3			
GHS200-260	259.2	72.0	19.5	1450	18.86	30	73	3.0	250	200	256
	432	120.0	15.2		21.81	30	82	3.2			
	518.4	144.0	12		22.89	30	74	3.3			
GHS200-260A	248.4	69.0	18	1450	16.91	22	72	2.9	250	200	256
	414	115.0	14		19.49	22	81	3.1			
	496.8	138.0	10.5		19.73	22	72	3.2			
GHS200-260B	237.6	66.0	15	1450	13.87	18.5	70	2.8	250	200	256
	396	110.0	12		16.18	18.5	80	3.0			
	475.2	132.0	9.7		17.93	18.5	70	3.1			
GHS200-320	345	95.8	35	1450	45.36	75	72.5	3.2	250	200	310
	575	159.7	30		56.26	75	83.5	3.3			
	690	191.7	25.5		60.27	75	79.5	3.4			
GHS200-320A	324	90.0	30	1450	37.28	55	71	3.1	250	200	310
	540	150.0	25.5		45.18	55	83	3.2			
	648	180.0	21		47.51	55	78	3.3			
GHS200-320B	302.4	84.0	26.5	1450	32.33	45	67.5	3.0	250	200	310
	504	140.0	22		36.82	45	82	3.1			
	604.8	168.0	18.3		38.89	45	77.5	3.2			
GHS200-400	390	108.3	59.5	1450	85.40	132	74	3.0	250	200	345
	650	180.6	53.5		112.74	132	84	3.8			
	780	216.7	48.5		125.64	132	82	4.5			
GHS200-400A	360	100.0	52.5	1450	73.53	110	70	2.9	250	200	345
	600	166.7	46.5		93.80	110	81	3.6			
	720	200.0	41.5		101.72	110	80	4.4			
GHS200-400B	330	91.7	41.5	1450	54.05	90	69	2.8	250	200	345
	550	152.8	36		66.57	90	81	3.5			
	660	183.3	31		71.43	90	78	4.2			
GHS200-500	330	91.7	90	1450	118.94	250	68	3.2	250	200	510
	550	152.8	87		160.88	250	81	4.0			
	660	183.3	84.5		189.85	250	80	4.8			
GHS200-500A	300	83.3	82.5	1450	97.68	200	69	3.0	250	200	510
	500	138.9	80		132.04	200	82.5	3.8			
	600	166.7	77.5		150.75	200	84	4.5			
GHS200-500B	270	75.0	73	1450	85.20	160	63	2.8	250	200	510
	450	125.0	71.5		112.34	160	78	3.6			
	540	150.0	69		126.84	160	80	4.2			
GHS250-320	522	145.0	32	1450	65.93	90	69	3.0	300	250	375
	870	241.7	27.5		78.03	90	83.5	4.8			
	1044	290.0	24		83.21	90	82	6.5			
GHS250-320A	480	133.3	29.5	1450	61.21	90	63	2.8	300	250	375
	800	222.2	25.5		67.75	90	82	4.5			
	960	266.7	22.5		70.45	90	83.5	6.2			



Параметры производительности

(4P)

Модель насоса	Производительность		Напор (м)	Скорость ном. (об/мин)	Мощность		К П Д η (%)	NPSHr (м)	Диаметр насоса (мм)		Вес (кг)
	(м ³ /ч)	(л/с)			Мощность на валу (кВт)	Двигатель (кВт)			Всасывание	Нагнетание	
GHS250-320B	450	125.0	28	1450	55.34	75	62	2.5	300	250	375
	750	208.3	24.5		61.78	75	81	4.2			
	900	250.0	22		65.76	75	82	6.0			
GHS250-320C	432	120.0	23.5	1450	45.32	75	61	2.4	300	250	375
	720	200.0	20		49.02	75	80	4.0			
	864	240.0	17.5		54.18	75	76	5.8			
GHS250-400	550	152.8	56.5	1450	112.09	200	75.5	3.0	300	250	455
	760	211.1	54		131.49	200	85	3.5			
	950	263.9	48.5		151.18	200	83	4.5			
GHS250-400A	360	100.0	45	1450	71.16	110	62	2.6	300	250	455
	600	166.7	43		87.83	110	80	3.2			
	720	200.0	40.5		95.68	110	83	4.2			
GHS250-400B	300	83.3	35	1450	51.52	75	55.5	2.3	300	250	455
	500	138.9	33		59.91	75	75	3.0			
	600	166.7	31		64.12	75	79	4.0			
GHS250-500	534	148.3	85.5	1450	177.63	315	70	3.0	300	250	630
	890	247.2	80		236.46	315	82	5.0			
	1068	296.7	74		265.71	315	81	7.0			
GHS250-500A	480	133.3	76	1450	148.28	250	67	2.8	300	250	630
	800	222.2	70.5		191.99	250	80	4.6			
	960	266.7	65.5		214.05	250	80	6.7			
GHS250-500B	450	125.0	68	1450	128.21	200	65	2.6	300	250	630
	750	208.3	63		163.92	200	78.5	4.4			
	900	250.0	58.4		181.19	200	79	6.5			
GHS300-320	720	200	39	1450	112	160	70	4.5	350	300	400
	1200	333	32		124	160	85	5.0			
	1440	400	30		147	160	86.5	5.5			
GHS300-320A	691	192	35	1450	98	132	64	4.2	350	300	400
	1152	320	29		113	132	80	5.0			
	1382	384	27.5		126	132	81	5.5			
GHS300-320B	626	174	33.5	1450	85	110	55	4.4	350	300	400
	1044	290	27.5		97.8	110	74	5.3			
	1253	348	24		104	110	78	5.7			
GHS300-400	831.6	231.0	52	1450	168.24	250	70	5.0	350	300	700
	1386	385.0	46.5		204.09	250	86	7.0			
	1663.2	462.0	42		217.41	250	87.5	8.0			
GHS300-400A	720	200.0	45	1450	135.75	200	65	4.8	350	300	700
	1200	333.3	40.5		163.40	200	81	6.5			
	1440	400.0	37		176.95	200	82	7.5			
GHS300-400B	594	165.0	38.5	1450	114.27	160	54.5	4.5	350	300	700
	990	275.0	35		127.52	160	74	6.0			
	1188	330.0	32.5		133.10	160	79	7.0			



Габаритные размеры

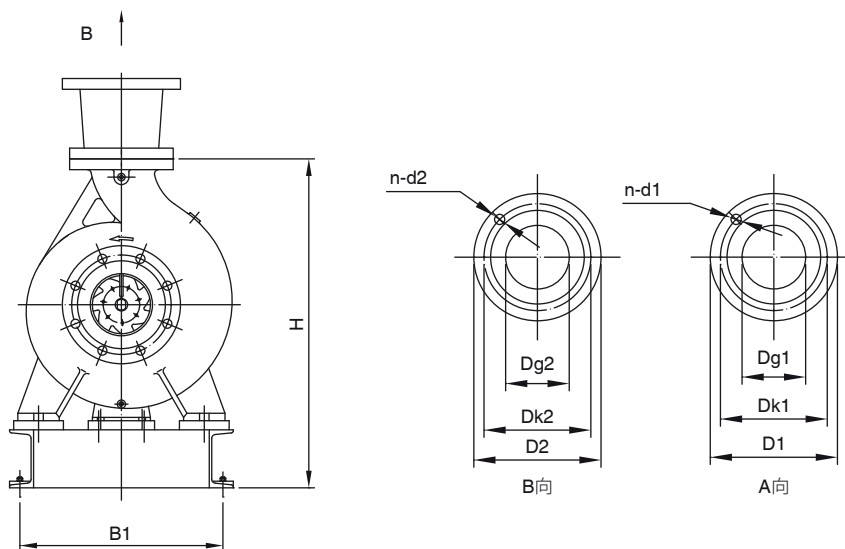
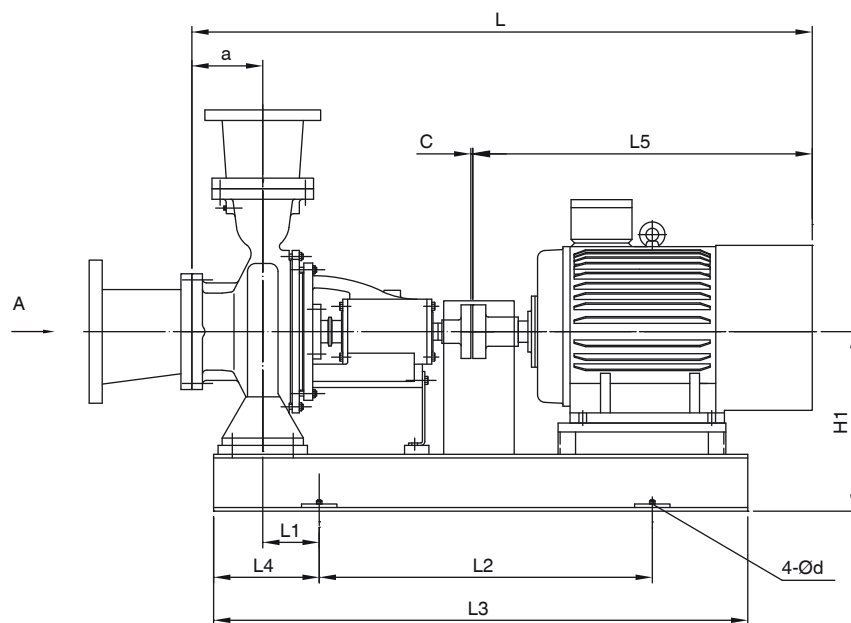

Монтажные размеры

Эта диаграмма применяется к насосам со стальным корпусом

Модель насоса	Двигатель		Монтажный размер насоса											Всасывающая труба				Нагнетательная труба				Общий вес (кг)		
	Ном. корпуса	(кВт)	a	L	L1	L2	L3	L4	L5	B1	H1	H	c	b	d	Dg1	Dk1	D1	n1-d1	Dg2	Dk2		D2	n2-d2
GHS32-130	Y90L-2	2.2	80	787	57	450	700	127	345	225	202	342	2	16	Ø19	/	/	/	/	Ø50	Ø125	Ø165	4-Ø18	79
	Y90S-2	1.5	80	762	57	450	675	127	320	225	187	327	2	16	Ø19	/	/	/	/	Ø50	Ø125	Ø165	4-Ø18	79
	Y80,-4	0.55	80	722	57	400	658	127	295	235	187	327	2	16	Ø19	/	/	/	/	/	/	/	/	70
GHS32-160	Y132S1-2	5.5	80	907	77	500	794	147	465	285	224	384	2	16	Ø19	/	/	/	/	Ø50	Ø125	Ø165	4-Ø18	131
	Y112M-2	4	80	862	67	450	745	137	420	255	224	384	2	16	Ø19	/	/	/	/	Ø50	Ø125	Ø165	4-Ø18	108
	Y80,-4	0.55	80	737	50	450	657	120	295	225	207	367	2	16	Ø19	/	/	/	/	/	/	/	/	78
GHS32-200	Y160M1-2	11	80	1092	90	580	945	160	650	325	252	432	2	16	Ø19	/	/	/	/	Ø50	Ø125	Ø165	4-Ø18	206
	Y132S2-2	7.5	80	907	61	500	794	131	465	285	235	415	2	16	Ø19	/	/	/	/	Ø50	Ø125	Ø165	4-Ø18	145
	Y90S-4	1.1	80	762	51	450	675	121	320	280	235	415	2	16	Ø19	/	/	/	/	/	/	/	/	94
GHS32-260	Y160L-2	18.5	100	1142	87.5	580	1000	170	680	325	272	497	2	16	Ø19	/	/	/	/	Ø50	Ø125	Ø165	4-Ø18	251
	Y160M2-2	15	100	1112	87.5	580	955	170	600	325	272	497	2	16	Ø19	/	/	/	/	Ø50	Ø125	Ø165	4-Ø18	237
	Y100L2-4	3	100	852	67.5	450	745	150	390	315	272	497	2	16	Ø19	/	/	/	/	/	/	/	/	129
GHS40-130	Y112M-2	4	80	862	83	450	750	153	420	255	190	330	2	16	Ø19	/	/	/	/	Ø65	Ø145	Ø185	4-Ø18	101
	Y100L-2	3	80	832	67	450	736	137	390	225	204	344	2	16	Ø19	/	/	/	/	Ø65	Ø145	Ø185	4-Ø18	90
	Y80,-4	0.55	80	737	67	400	660	137	295	225	187	327	2	16	Ø19	/	/	/	/	/	/	/	/	72
GHS40-160	Y132S2-2	7.5	80	907	77	500	794	147	465	285	224	384	2	16	Ø19	/	/	/	/	Ø65	Ø145	Ø185	4-Ø18	137
	Y132S1-2	5.5	80	907	77	500	794	147	465	285	224	384	2	16	Ø19	/	/	/	/	Ø65	Ø145	Ø185	4-Ø18	132
	Y112M-2	4	80	862	67	450	745	137	420	255	224	384	2	16	Ø19	/	/	/	/	Ø65	Ø145	Ø185	4-Ø18	109
	Y90S-4	1.1	80	762	57	450	674	127	320	250	224	384	2	16	Ø19	/	/	/	/	/	/	/	/	85
GHS40-200	Y160M1-2	11	100	1112	90	580	945	160	650	325	252	432	2	16	Ø19	/	/	/	/	Ø65	Ø145	Ø185	4-Ø18	210
	Y90L-4	1.5	100	807	51	450	700	121	345	278	235	415	2	16	Ø19	/	/	/	/	/	/	/	/	103
GHS40-260	Y180M-2	22	100	1147	117.5	580	975	200	685	350	272	497	2	16	Ø19	/	/	/	/	Ø65	Ø145	Ø185	4-Ø18	286
	Y160L-2	18.5	100	1142	87.5	580	1000	170	680	325	272	497	2	16	Ø19	/	/	/	/	Ø65	Ø145	Ø185	4-Ø18	253
	Y100L2-4	3	100	852	67.5	450	745	150	390	315	272	497	2	16	Ø19	/	/	/	/	Ø65	Ø145	Ø185	4-Ø18	131
GHS40-320	Y200L2-2	37	125	1377	120.5	750	1160	203	780	395	342	592	2	16	Ø24	Ø80	Ø160	Ø200	8-Ø18	Ø65	Ø145	Ø185	4-Ø18	413
	Y200L1-2	30	125	1377	120.5	750	1160	203	780	395	342	592	2	16	Ø24	Ø80	Ø160	Ø200	8-Ø18	Ø65	Ø145	Ø185	4-Ø18	394
	Y180M-2	22	125	1287	114	680	1081	197	690	350	315	540	2	16	Ø19	Ø80	Ø160	Ø200	8-Ø18	Ø65	Ø145	Ø185	4-Ø18	350
	Y132S-4	5.5	125	1062	105	580	914.5	187.5	465	350	292	542	2	16	Ø19	/	/	/	/	Ø65	Ø145	Ø185	4-Ø18	214
GHS50-130	Y132S2-2	7.5	100	927	77	500	794	147	465	285	224	384	2	16	Ø19	Ø80	Ø160	Ø200	8-Ø18	Ø80	Ø160	Ø200	8-Ø18	135
	Y132S1-2	5.5	100	927	77	500	794	147	465	285	224	384	2	16	Ø19	Ø80	Ø160	Ø200	8-Ø18	Ø80	Ø160	Ø200	8-Ø18	130
	Y90S-4	1.1	100	782	57	450	674	127	320	250	224	384	2	16	Ø19	Ø80	Ø160	Ø200	8-Ø18	Ø65	Ø145	Ø185	4-Ø18	83
GHS50-160	Y160M1-2	11	100	1112	90	580	945	160	650	325	252	432	2	16	Ø19	Ø80	Ø160	Ø200	8-Ø18	Ø80	Ø160	Ø200	8-Ø18	204
	Y90L-4	1.5	100	807	51	450	700	121	345	278	235	415	2	16	Ø19	Ø80	Ø160	Ø200	8-Ø18	Ø65	Ø145	Ø185	4-Ø18	97
GHS50-200	Y160L-2	18.5	100	1142	90	580	990	160	680	325	252	452	2	16	Ø19	Ø80	Ø160	Ø200	8-Ø18	Ø80	Ø160	Ø200	8-Ø18	236
	Y160M2-2	15	100	1112	90	580	945	160	650	325	252	452	2	16	Ø19	Ø80	Ø160	Ø200	8-Ø18	Ø80	Ø160	Ø200	8-Ø18	222
	Y100L1-4	2.2	100	852	69	450	736	139	390	285	235	435	2	16	Ø19	Ø80	Ø160	Ø200	8-Ø18	Ø65	Ø145	Ø185	4-Ø18	111
GHS50-260	Y200L2-2	37	100	1242	137.5	630	1050	220	780	395	310	535	2	16	Ø24	Ø80	Ø160	Ø200	8-Ø18	Ø80	Ø160	Ø200	8-Ø18	386
	Y200L1-2	30	100	1242	137.5	630	1050	220	780	395	310	535	2	16	Ø24	Ø80	Ø160	Ø200	8-Ø18	Ø80	Ø160	Ø200	8-Ø18	370
	Y132S-4	5.5	100	927	77	500	805	159.5	465	315	255	480	2	16	Ø19	Ø80	Ø160	Ø200	8-Ø18	Ø65	Ø145	Ø185	4-Ø18	164
GHS50-320	Y280S-2	75	125	1564	92.5	900	1355	175	965	540	396	676	4	16	Ø28	Ø80	Ø160	Ø200	8-Ø18	Ø80	Ø160	Ø200	8-Ø18	793
	Y225M-2	45	125	1409	94	800	1189	176.5	810	440	341	621	4	16	Ø24	Ø80	Ø160	Ø200	8-Ø18	Ø80	Ø160	Ø200	8-Ø18	618
	Y160M-4	11	125	1248	92.5	680	1065	175	650	395	317	597	3	16	Ø24	Ø80	Ø160	Ø200	8-Ø18	Ø65	Ø145	Ø185	4-Ø18	293
	Y132M-4	7.5	125	1103	127.5	630	955	210	505	395	343	623	3	16	Ø24	Ø80	Ø160	Ø200	8-Ø18	Ø65	Ø145	Ø185	4-Ø18	246
GHS65-130	Y160M1-2	11	100	1112	87.5	580	925	170	650	325	252	432	2	16	Ø19	Ø100	Ø180	Ø220	8-Ø18	Ø100	Ø180	Ø220	8-Ø18	205
	Y132S2-2	7.5	100	927	87.5	500	805	170	465	285	252	432	2	16	Ø19	Ø100	Ø180	Ø220	8-Ø18	Ø100	Ø180	Ø220	8-Ø18	144
	Y90L-4	1.5	100	807	67.5	440	710	150	345	285	252	432	2	16	Ø19	Ø100	Ø180	Ø220	8-Ø18	Ø80	Ø160	Ø200	8-Ø18	98
GHS65-160	Y160L-2	18.5	100	1142	87.5	580	1000	170	680	325	252	452	2	16	Ø19	Ø100	Ø180	Ø220	8-Ø18	Ø100	Ø180	Ø220	8-Ø18	233
	Y160M2-2	15	100	1112	87.5	580	925	170	650	325	252	452	2	16	Ø19	Ø100	Ø180	Ø220	8-Ø18	Ø100	Ø180	Ø220	8-Ø18	219
	Y160M1-2	11	100	1112	87.5	580	925	170	650	325	252	452	2	16	Ø19	Ø100	Ø180	Ø220	8-Ø18	Ø100	Ø180	Ø220	8-Ø18	209
	Y100L1-4	2.2	100	852	67.5	450	745	150	390	285	252	452	2	16	Ø19	Ø100	Ø180	Ø220	8-Ø18	Ø80	Ø160	Ø200	8-Ø18	108



Монтажные размеры

Эта диаграмма применяется к насосам со стальным корпусом

Модель насоса	Двигатель		Монтажный размер насоса											Всасывающая труба				Нагнетательная труба				Общий вес (кг)		
	Ном. корпуса	(кВт)	a	L	L1	L2	L3	L4	L5	B1	H1	H	c	b	d	Dg1	Dk1	D1	n1-d1	Dg2	Dk2		D2	n2-d2
GHS65-200G	Y200L1-2	30	100	1339	127.5	700	1145	210	780	395	320	545	3	16	Ø24	Ø125	Ø210	Ø250	8-Ø18	Ø100	Ø180	Ø220	8-Ø18	373
	Y180M-2	22	100	1244	147.5	650	1069	230	685	350	296	521	3	16	Ø19	Ø125	Ø210	Ø250	8-Ø18	Ø100	Ø180	Ø220	8-Ø18	295
GHS65-200	Y112M-4	4	100	882	72.5	450	755	155	420	315	272	497	2	16	Ø19	Ø125	Ø210	Ø250	8-Ø18	Ø80	Ø160	Ø200	8-Ø18	137
GHS65-260	Y250M-2	55	100	1493	162	800	1304	262	920	495	401	651	3	16	Ø24	Ø125	Ø210	Ø250	8-Ø18	Ø100	Ø180	Ø220	8-Ø18	584
	Y225M-2	45	100	1383	140	750	1205	240	810	430	341	591	3	16	Ø24	Ø125	Ø210	Ø250	8-Ø18	Ø100	Ø180	Ø220	8-Ø18	479
	Y132M-4	7.5	100	1078	105	580	970	205	505	355	292	542	3	16	Ø19	Ø125	Ø210	Ø250	8-Ø18	Ø80	Ø160	Ø200	8-Ø18	212
GHS65-320H	Y315S-2	110	125	1774	190	870	1474	290	1175	620	480	760	4	16	Ø28	Ø125	Ø210	Ø250	8-Ø18	Ø100	Ø180	Ø220	8-Ø18	1296
	Y280M-2	90	125	1614	180	880	1435	280	1015	550	436	716	4	16	Ø28	Ø125	Ø210	Ø250	8-Ø18	Ø100	Ø180	Ø220	8-Ø18	925
	Y280S-2	75	125	1564	172	880	1374	272	965	550	440	720	4	16	Ø28	Ø125	Ø210	Ø250	8-Ø18	Ø100	Ø180	Ø220	8-Ø18	845
GHS65-320	Y160L-4	15	125	1278	95	680	1126	195	680	395	317	597	3	16	Ø24	Ø125	Ø210	Ø250	8-Ø18	Ø80	Ø160	Ø200	8-Ø18	315
	Y160M-4	11	125	1248	95	680	1080	195	650	395	340	620	3	16	Ø24	Ø125	Ø210	Ø250	8-Ø18	Ø80	Ø160	Ø200	8-Ø18	302
GHS80-160	Y200L1-2	30	125	1267	137.5	630	1050	220	780	395	310	535	2	16	Ø24	Ø150	Ø240	Ø285	8-Ø22	Ø125	Ø210	Ø250	8-Ø18	357
	Y180M-2	22	125	1172	85	580	975	200	685	350	272	497	2	16	Ø19	Ø150	Ø240	Ø285	8-Ø22	Ø125	Ø210	Ø250	8-Ø18	279
	Y160L-2	18.5	125	1167	87.5	580	1000	170	680	325	272	497	2	16	Ø19	Ø150	Ø240	Ø285	8-Ø22	Ø125	Ø210	Ø250	8-Ø18	246
	Y100L2-4	3	125	877	67.5	450	745	150	390	315	272	497	2	16	Ø19	Ø150	Ø240	Ø285	8-Ø22	Ø100	Ø180	Ø220	8-Ø18	124
GHS80-200	Y225M-2	45	125	1408	152.5	750	1188	235	810	430	343	593	3	16	Ø24	Ø150	Ø240	Ø285	8-Ø22	Ø125	Ø210	Ø250	8-Ø18	462
	Y200L2-2	37	125	1378	147.5	700	1165	230	780	395	316	566	3	16	Ø24	Ø150	Ø240	Ø285	8-Ø22	Ø125	Ø210	Ø250	8-Ø18	397
	Y132M-4	7.5	125	1103	112.5	550	955	195	505	350	275	525	3	16	Ø24	Ø150	Ø240	Ø285	8-Ø22	Ø100	Ø180	Ø220	8-Ø18	197
GHS80-260	Y280S-2	75	125	1563	160	850	1373	260	965	555	440	720	3	16	Ø28	Ø150	Ø240	Ø285	8-Ø22	Ø125	Ø210	Ø250	8-Ø18	758
	Y160M-4	11	125	1248	120	630	1083	220	650	395	316	596	3	16	Ø24	Ø150	Ø240	Ø285	8-Ø22	Ø100	Ø180	Ø220	8-Ø18	279
GHS80-320H	Y315S-2	110	125	1774	150	1000	1474	250	1175	625	502	817	4	16	Ø28	Ø150	Ø240	Ø285	8-Ø22	Ø125	Ø210	Ø250	8-Ø18	1342
	Y280M-2	90	125	1614	184	880	1428	284	1015	550	440	755	4	16	Ø28	Ø150	Ø240	Ø285	8-Ø22	Ø125	Ø210	Ø250	8-Ø18	958
GHS80-320	Y180M-4	18.5	125	1283	105	750	1145	205	685	395	366	681	3	16	Ø24	Ø125	Ø210	Ø250	8-Ø18	Ø100	Ø180	Ø220	8-Ø18	370
	Y160L-4	15	125	1278	105	750	1100	205	680	395	366	681	3	16	Ø24	Ø125	Ø210	Ø250	8-Ø18	Ø100	Ø180	Ø220	8-Ø18	327
	Y160M-4	11	125	1248	105	750	1055	205	650	395	342	657	3	16	Ø24	Ø125	Ø210	Ø250	8-Ø18	Ø100	Ø180	Ø220	8-Ø18	307
GHS80-400	Y200L-4	30	125	1428	140	780	1230	240	780	420	422	777	3	16	Ø24	Ø125	Ø210	Ø250	8-Ø18	Ø100	Ø180	Ø220	8-Ø18	504
GHS100-200	Y280S-2	75	125	1563	160	850	1373	260	965	555	440	720	3	16	Ø28	Ø200	Ø295	Ø340	12-Ø22	Ø150	Ø240	Ø285	8-Ø22	752
	Y250M-2	55	125	1518	162	800	1304	262	920	495	401	681	3	16	Ø24	Ø200	Ø295	Ø340	12-Ø22	Ø150	Ø240	Ø285	8-Ø22	588
	Y225M-2	45	125	1408	140	750	1205	240	810	430	341	621	3	16	Ø24	Ø200	Ø295	Ø340	12-Ø22	Ø150	Ø240	Ø285	8-Ø22	483
	Y160M-4	11	125	1248	120	630	1083	220	650	395	316	596	3	16	Ø24	Ø200	Ø295	Ø340	12-Ø22	Ø125	Ø210	Ø250	8-Ø18	273
GHS100-260H	Y315S-2	110	140	1789	190	870	1474	290	1175	620	480	760	4	16	Ø28	Ø200	Ø295	Ø340	12-Ø22	Ø150	Ø240	Ø285	8-Ø22	1146
	Y280M-2	90	140	1629	180	880	1435	280	1015	550	436	716	4	16	Ø28	Ø200	Ø295	Ø340	12-Ø22	Ø150	Ø240	Ø285	8-Ø22	857
GHS100-260	Y160L-4	15	140	1293	95	680	1126	195	680	395	317	597	3	16	Ø24	Ø200	Ø295	Ø340	12-Ø22	Ø125	Ø210	Ø250	8-Ø18	311
GHS100-320	Y180L-4	22	140	1338	105	750	1140	205	725	395	362	677	3	16	Ø24	Ø150	Ø240	Ø285	8-Ø22	Ø125	Ø210	Ø250	8-Ø18	402
	Y180M-4	18.5	140	1298	105	750	1145	205	685	395	366	681	3	16	Ø24	Ø150	Ø240	Ø285	8-Ø22	Ø125	Ø210	Ø250	8-Ø18	384
GHS100-400	Y225M-4	45	140	1513	136.5	820	1320	260	840	540	442	797	3	16	Ø28	Ø150	Ø240	Ø285	8-Ø22	Ø125	Ø210	Ø250	8-Ø18	630
	Y225S-4	37	140	1488	140	820	1290	260	815	540	445	800	3	16	Ø28	Ø150	Ø240	Ø285	8-Ø22	Ø125	Ø210	Ø250	8-Ø18	595
GHS125-200	Y280M-2	90	140	1628	184	880	1428	284	1015	550	440	755	3	16	Ø28	Ø250	Ø355	Ø405	12-Ø26	Ø200	Ø295	Ø340	12-Ø22	865
	Y160M-4	11	140	1263	105	750	1065	205	650	395	342	657	3	16	Ø24	Ø200	Ø295	Ø340	12-Ø22	Ø150	Ø240	Ø285	8-Ø22	300
GHS125-260	Y180L-4	22	140	1338	105	750	1140	205	725	395	362	717	3	16	Ø24	Ø200	Ø295	Ø340	12-Ø22	Ø150	Ø240	Ø285	8-Ø22	383
	Y180M-4	18.5	140	1298	105	750	1145	205	685	395	366	721	3	16	Ø24	Ø200	Ø295	Ø340	12-Ø22	Ø150	Ø240	Ø285	8-Ø22	365
GHS125-320	Y200L-4	30	140	1453	110	800	1260	230	780	490	422	777	3	16	Ø24	Ø200	Ø295	Ø340	12-Ø22	Ø150	Ø240	Ø285	8-Ø22	516
	Y180L-4	22	140	1398	110	780	1220	230	725	495	423	778	3	16	Ø24	Ø200	Ø295	Ø340	12-Ø22	Ø150	Ø240	Ø285	8-Ø22	449
GHS125-400	Y280S-4	75	140	1638	190	910	1451	310	965	550	475	875	3	16	Ø28	Ø200	Ø295	Ø340	12-Ø22	Ø150	Ø240	Ø285	8-Ø22	891
	Y250M-4	55	140	1593	150	870	1385	270	920	490	471	871	3	16	Ø28	Ø200	Ø295	Ø340	12-Ø22	Ø150	Ø240	Ø285	8-Ø22	726
GHS125-500	Y315S-4	110	180	2069	160	1150	1724	280	1215	625	555	1055	4	16	Ø28	Ø200	Ø295	Ø340	12-Ø22	Ø150	Ø240	Ø285	8-Ø22	1521
	Y280S-4	75	180	1819	220	870	1597	340	965	620	535	1035	4	16	Ø28	Ø200	Ø295	Ø340	12-Ø22	Ø150	Ø240	Ø285	8-Ø22	1044
	Y250M-4	55	180	1774	220	840	1525	340	920	550	535	1035	4	16	Ø28	Ø200	Ø295	Ø340	12-Ø22	Ø150	Ø240	Ø285	8-Ø22	926
GHS150-200	Y180M-4	18.5	160	1343	115	780	144.5	235	685	550	395	795	3	16	Ø24	Ø250	Ø355	Ø405	12-Ø26	Ø200	Ø295	Ø340		

Монтажные размеры

Эта диаграмма применяется к насосам со стальным корпусом

Модель насоса	Двигатель		Монтажный размер насоса											Всасывающая труба				Нагнетательная труба				Общий вес (кг)		
	Ном. корпуса	(кВт)	a	L	L1	L2	L3	L4	L5	B1	H1	H	c	b	d	Dg1	Dk1	D1	n1-d1	Dg2	Dk2		D2	n2-d2
GHS150-260	Y200L-4	30	160	1473	120	800	1258	240	780	440	392	747	3	16	Ø24	Ø250	Ø355	Ø405	12-Ø26	Ø200	Ø295	Ø340	12-Ø22	495
	Y180L-4	22	160	1418	119	750	1223	239	725	440	396	751	3	16	Ø24	Ø250	Ø355	Ø405	12-Ø26	Ø200	Ø295	Ø340	12-Ø22	444
GHS150-320	Y250M-4	55	160	1619	150	870	1385	270	920	540	440	840	3	16	Ø28	Ø250	Ø355	Ø405	12-Ø26	Ø200	Ø295	Ø340	12-Ø22	696
	Y225M-4	45	160	1539	140	820	1320	260	840	540	436	836	3	16	Ø28	Ø250	Ø355	Ø405	12-Ø26	Ø200	Ø295	Ø340	12-Ø22	626
GHS150-400	Y280M-4	90	160	1709	190	910	1510	310	1015	550	475	925	4	16	Ø28	Ø250	Ø355	Ø405	12-Ø26	Ø200	Ø295	Ø340	12-Ø22	942
	Y280S-4	75	160	1659	190	910	1454	310	965	550	475	925	4	16	Ø28	Ø250	Ø355	Ø405	12-Ø26	Ø200	Ø295	Ø340	12-Ø22	927
GHS150-500	Y315L1-4	160	180	2169	230	1100	1800	350	1315	625	560	1060	4	16	Ø28	Ø250	Ø355	Ø405	12-Ø26	Ø200	Ø295	Ø340	12-Ø22	1846
	Y315M-4	132	180	2094	220	1000	1760	340	1240	625	560	1060	4	16	Ø28	Ø250	Ø355	Ø405	12-Ø26	Ø200	Ø295	Ø340	12-Ø22	1638
	Y315S-4	110	180	2069	160	1150	1724	280	1215	625	555	1055	4	16	Ø28	Ø250	Ø355	Ø405	12-Ø26	Ø200	Ø295	Ø340	12-Ø22	1544
GHS200-260	Y200L-4	30	180	1509	110	800	1275	230	780	550	396	796	3	16	Ø28	Ø300	Ø410	Ø460	12-Ø26	Ø300	Ø410	Ø460	12-Ø26	566
	Y180L-4	22	180	1454	110	800	1239	230	725	550	396	796	3	16	Ø28	Ø300	Ø410	Ø460	12-Ø26	Ø300	Ø410	Ø460	12-Ø26	524
	Y180M-4	18.5	180	1423	110	750	1199.5	230	690	550	396	796	3	16	Ø28	Ø300	Ø410	Ø460	12-Ø26	Ø300	Ø410	Ø460	12-Ø26	508
GHS200-320	Y280S-4	75	200	1839	190	910	1578	310	965	540	540	990	4	16	Ø28	Ø300	Ø410	Ø460	12-Ø26	Ø300	Ø410	Ø460	12-Ø26	952
	Y250M-4	55	200	1794	130	900	1525	250	920	540	540	990	4	16	Ø28	Ø300	Ø410	Ø460	12-Ø26	Ø300	Ø410	Ø460	12-Ø26	802
	Y225M-4	45	200	1714	130	900	1461	250	840	540	520	970	4	16	Ø28	Ø300	Ø410	Ø460	12-Ø26	Ø300	Ø410	Ø460	12-Ø26	733
GHS200-400	Y315M-4	132	200	2114	240	1000	1770	360	1240	625	540	1040	4	16	Ø28	Ø300	Ø410	Ø460	12-Ø26	Ø300	Ø410	Ø460	12-Ø26	1563
	Y315S-4	110	200	2089	160	1100	1720	280	1215	625	535	1035	4	16	Ø28	Ø300	Ø410	Ø460	12-Ø26	Ø300	Ø410	Ø460	12-Ø26	1469
	Y280M-4	90	200	1889	160	1000	1655	280	1015	540	535	1035	4	16	Ø28	Ø300	Ø410	Ø460	12-Ø26	Ø300	Ø410	Ø460	12-Ø26	1096
GHS200-500	Y355M-4	250	210	2453	230	1100	1923	400	1565	725	625	1125	4	16	Ø28	Ø300	Ø410	Ø460	12-Ø26	Ø300	Ø410	Ø460	12-Ø26	2587
	Y315L2-4	200	210	2204	210	1100	1850	380	1315	710	585	1085	4	16	Ø28	Ø300	Ø410	Ø460	12-Ø26	Ø300	Ø410	Ø460	12-Ø26	1962
	Y315L1-4	160	210	2204	210	1100	1850	380	1315	710	585	1085	4	16	Ø28	Ø300	Ø410	Ø460	12-Ø26	Ø300	Ø410	Ø460	12-Ø26	1833
GHS250-320	Y280M-4	90	200	1889	190	910	1680	335	1015	595	540	1065	4	16	Ø28	Ø350	Ø470	Ø520	16-Ø26	Ø350	Ø470	Ø520	16-Ø26	1131
	Y280S-4	75	200	1839	190	900	1629	335	965	595	540	1065	4	16	Ø28	Ø350	Ø470	Ø520	16-Ø26	Ø350	Ø470	Ø520	16-Ø26	1027
GHS250-400	Y315L2-4	200	250	2239	210	1100	1850	380	1315	710	585	1085	4	16	Ø28	Ø350	Ø470	Ø520	16-Ø26	Ø350	Ø470	Ø520	16-Ø26	1799
	Y315S-4	110	250	2139	130	1100	1740	300	1215	705	585	1085	4	16	Ø28	Ø350	Ø470	Ø520	16-Ø26	Ø350	Ø470	Ø520	16-Ø26	1498
	Y280S-4	75	250	1889	130	1000	1645	300	965	705	585	1085	4	16	Ø28	Ø350	Ø470	Ø520	16-Ø26	Ø350	Ø470	Ø520	16-Ø26	1021
GHS250-500	Y355L2-4	315	240	2683	230	1100	2123	400	1565	725	650	1195	4	16	Ø28	Ø350	Ø470	Ø520	16-Ø26	Ø350	Ø470	Ø520	16-Ø26	2877
	Y355M-4	250	240	2683	230	1100	2123	400	1565	725	650	1195	4	16	Ø28	Ø350	Ø470	Ø520	16-Ø26	Ø350	Ø470	Ø520	16-Ø26	2726
GHS300-320	Y315L1-4	160	260	2454	210	1100	2055	380	1315	720	605	1165	4	16	Ø28	Ø400	Ø525	Ø580	16-Ø30	Ø400	Ø525	Ø580	16-Ø30	1440
	Y315M-4	132	260	2379	210	1100	2020	380	1240	720	605	1165	4	16	Ø28	Ø400	Ø525	Ø580	16-Ø30	Ø400	Ø525	Ø580	16-Ø30	1615
	Y315S-4	110	260	2354	210	1100	1969	380	1215	720	605	1165	4	16	Ø28	Ø400	Ø525	Ø580	16-Ø30	Ø400	Ø525	Ø580	16-Ø30	1775
GHS300-400	Y355M-4	250	280	2579	260	1300	2168	430	1420	785	705	1305	4	16	Ø28	Ø400	Ø525	Ø580	16-Ø30	Ø400	Ø525	Ø580	16-Ø30	2807
	Y315L2-4	200	280	2474	257.5	1250	2055	427.5	1315	785	705	1305	4	16	Ø28	Ø400	Ø525	Ø580	16-Ø30	Ø400	Ø525	Ø580	16-Ø30	2182
	Y315L1-4	160	280	2474	257.5	1250	2055	427.5	1315	785	705	1305	4	16	Ø28	Ø400	Ø525	Ø580	16-Ø30	Ø400	Ø525	Ø580	16-Ø30	2053

- 1) Вышеуказанный размер двигателя соответствует насосу с двигателем стандартной конфигурации GSD серии Y2.
- 2) Всасывающий и нагнетательный трубопроводы не входят в стандартную заводскую компоновку.



欢迎索取以下产品型录



泵系列

潜水泵系列 | 陆上泵系列 | 特种泵系列



搅拌推流系列

搅拌机系列 | 推流器系列



供氧曝气系列

曝气机系列 | 曝气盘系列 | 曝气管系列



风机系列

三叶罗茨鼓风机系列 | 增压罗茨鼓风机 | 沉水式风机 | 空气悬浮离心鼓风机



污泥处理设备

带式脱水机 | 厢式压滤机 | 非金属矩形刮泥机 | 浅层高效气浮设备



智能化系列

EP6 物联监控管理系统 | 空气质量管理系统 | RS-485 传感器



反应器及套装设备

芬顿反应系统 | MBR生物膜反应器 | 预制泵站 | 一体化污水处理设备



耗材药剂及相关设备

生物绳 | PAC 聚合氯化铝 | PAM 聚丙烯酰胺 | 泡药设备



川源

环保设备和技术服务的专业伙伴

400-657-9066

Мы оставляем за собой право вносить изменения в содержание без предварительного уведомления.
Все права защищены. CY-K9

